

MOOG

J124-046 Series MMC-Moog Motion Controller For Clamp and V/P Control in Injection Molding

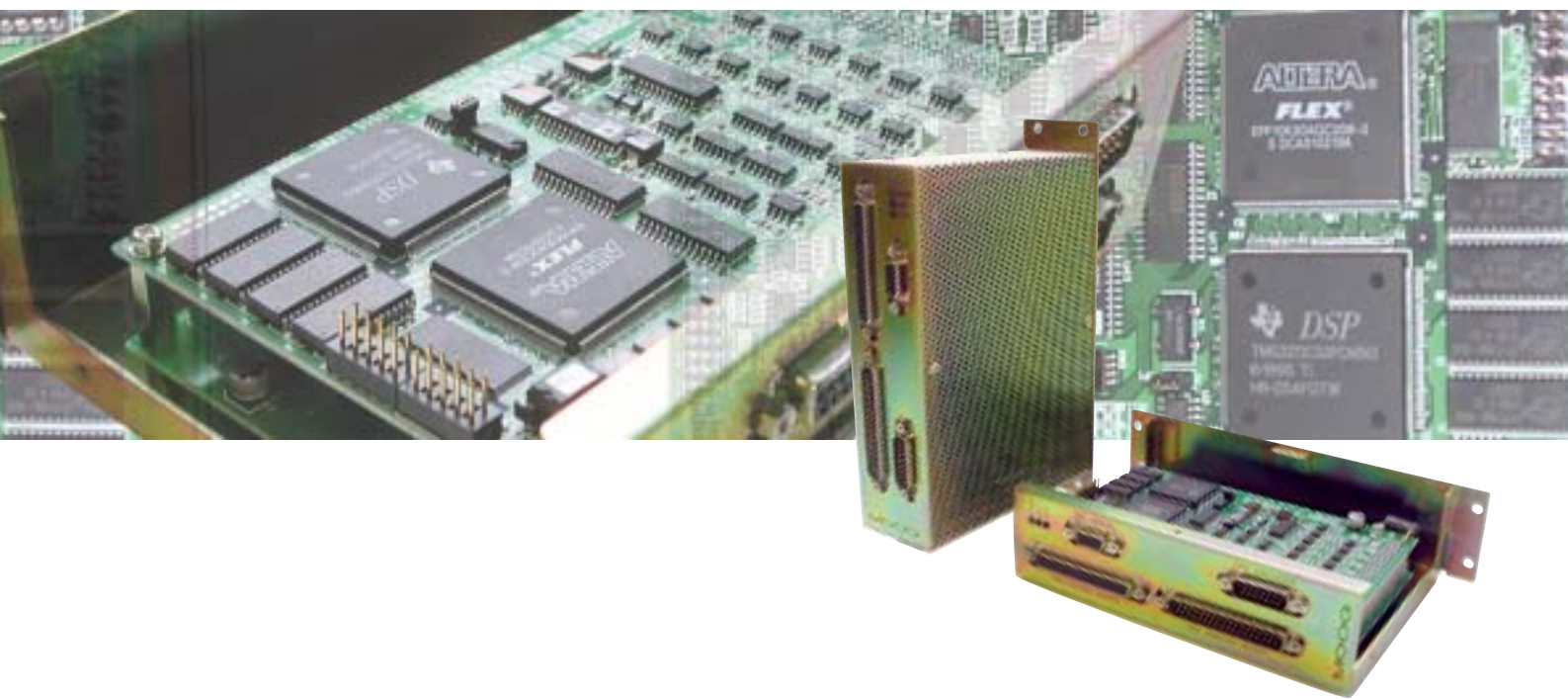

Table of contents

Section	Page
Introduction	2
Overview	2
Package	3
Monitoring(Optional)	6
Technical data	7
Interface	8
Installation	10
Ordering Information	11

Introduction

For over five decades, MOOG has pioneered the design and manufactures servocontrol products and systems that provide performance excellence for our customers. MOOG products and systems provide precise control of position, velocity, force, pressure, acceleration, and other critical parameters associated with plastics machinery.

MOOG has the range of products and depth of experience in closed loop systems to deliver solutions for plastics machinery applications. Known globally for quality and reliability, extensive product range includes servovalves, brushless motors, integrated hydraulic manifolds, actuators and digital servo controller.

Benefits of MOOG `s Systems Solutions

- Produce improved machine performance even in high-force and high-response applications.
- Design software technology offers numerous advantages from precision positioning to effective control of critical parameters in harsh environments.
- User friendly and easy set up for closed system tunings by GOUI.

Overview

The MOOG Motion Controller (MMC) controls the hydraulic cylinders (2-axes maximum) by closed loop control and also controls the synchronization between two axes with MOOG high performance servovalve.

This controller has a Digital Signal Processor (DSP), digital and analog interface and encoder (incremental) input port for controlling the cylinder.

The control software (control algorithm) is programmable for each application (in "C" language).

The parameters (Gain, Profile, etc.) can be adjusted by serial communication from a PC (RS422) using GOUI (Graphical Operator User Interface), and stored in the flash memory on this controller board. So once parameters are set and stored, this controller works as a standalone controller.

1. Fields of application:

- Injection Molding
- Other controls for:
 - ◆ Injection Process
 - ◆ Mold clamp Process
 - ◆ Positioning controls
 - ◆ Pressure controls
 - ◆ Velocity controls
 - ◆ Force controls

This controller is fit to each application for plastics machinery.

2. Software:

- Programming in "C" language
- MOOG provides the suitable software for each application to meet user's requirements

3. Operation:

- GOUI screen is pre-set by MOOG
- Each control parameter is adjusted by serial communication from PC (RS422/RS232C)
- Standalone control after setting the parameter

4. Machine process interface with PLC:

- 16ch digital inputs and outputs each
- Analog inputs
- RS422

5. Axis control:

- Feed back sensor
 - (1) Incremental encoder
 - (2) Analog input +/-10V
- Servovalve input:
+/-10V or +/-10mA of 2ch
- Programmable Control algorithms:
 - (1) PID control
 - (2) Feed forward control
 - (3) Adjustable Gain control
 - (4) Synchronization controls of each 2 axes
 - (5) Velocity compensation
 - (6) Etc....

Package

1. Parts included in the package:

This controller (J124-046-xxx) consists of three parts for each application as a package.

- (1) 2-axes controller box
(Model No. J124-040-001, the hardware itself)
- (2) Control software
(Pats No. Cxxxxx-xxx-xxx: stored in the flash memory on the controller card)
- (3) GOUI screen files for parameter set up
(Part No. Cxxxxx-xxx: one floppy disk, 3.5inch, 2HD)

2. Control software:

The software developed for each application includes most of the functionality, which are requested by the customer.

For example, it is designed for 2-axes closed loop position control with synchronization control.

The software is programmed and stored in the flash memory on the controller board so that it can run as a stand-alone controller.

3. GOUI Screen files for parameter setting:

Parameters in the control software can be set from PC via serial communication.

MOOG GOUI is the standard communication software.

MOOG programs screen files for parameter setting. User also can program/modify the screen file to meet user's the requirement.

GOUI

MOOG GOUI Package is a standard Windows based tool used with the MMC.

The GOUI is used as a tool for the users friendly adjustment, tuning of the controller parameters. The appearance and contents of GOUI screens can easily be customized via the use of text based display definition files. Fields within the file allow for the placement of (for example) LED's, Buttons and Numeric Controls. These can be for the display or modification of the controller parameters.

In addition, the GOUI allows the functionality such as upload and download of the parameter file (log file).

1. GOUI Designer Requirements

The following system is required to use GOUI,

- (1) Minimum PC requirement
 - CPU (Pentium) 75M Hz or above
 - RAM 8M bytes
 - Hard Disk 10M bytes

- (2) Operating System
 - Windows NT, 2000, & XP
- (3) Screens sizes to fit
 - 640x480 display,
 - (No scroll bars required).
 - A VGA resolution
 - or HIGHER video resolution.

2. Communication Link between GOUI and the controller

The GOUI uses the serial port of a PC to communicate with the MMC via the MOOG "Set-Up Link" protocol. The GOUI software and the physical link between the PC and the controller must both be configured correctly.

3. Cable for Serial Communication

Since the MMC serial communication is RS422 and the PC is equipped with a RS232C communication port, an RS422 to RS232C converter is necessary.

User can purchase this converter and related cables from MOOG as bellow figure.

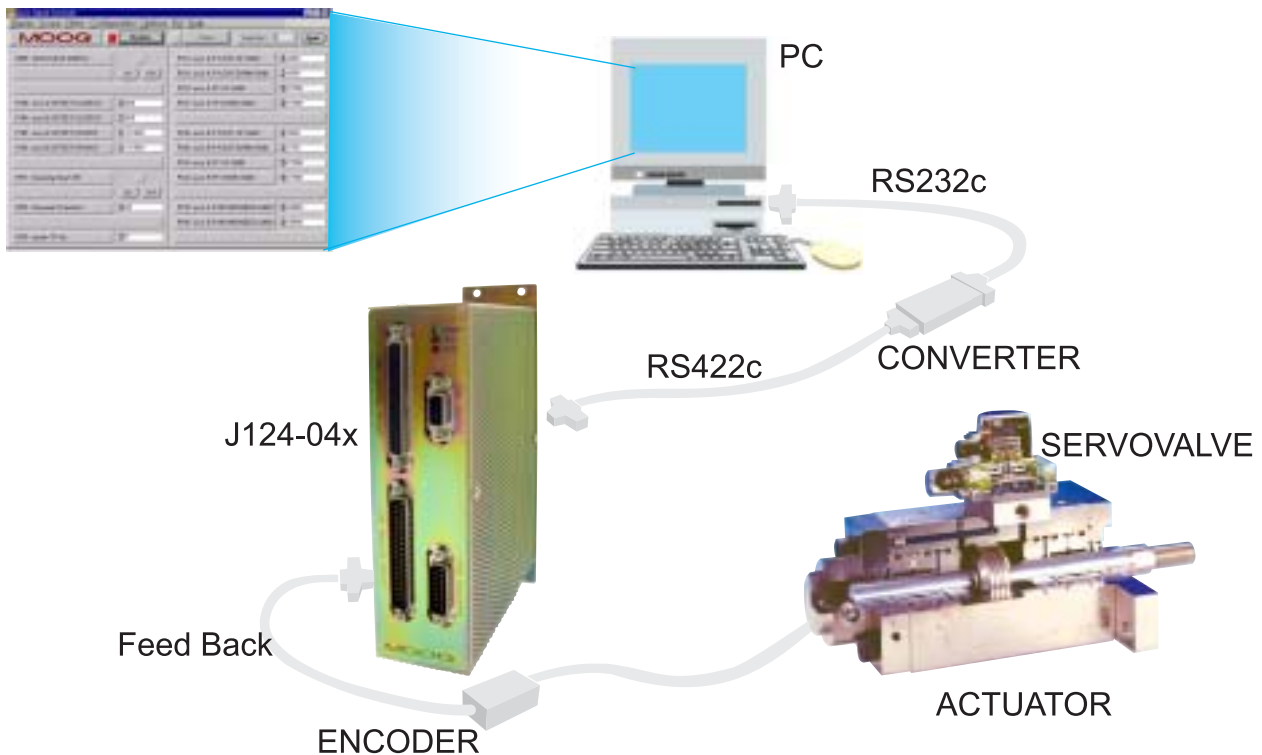

4. GOUI Screen example

A GOUI screen is created by defining a line of text in a definition file for each of the GOUI screen display lines. These definition files always have an .OUI extension. Each line of the .OUI text file contains fields, which define all parameters related to the display line.

The figure below is the example of the screen. A description of the various controls (e.g. buttons, numeric controls etc.) which can be created, and the format of the GOUI lines which are required to create them are outlined in the user manual .



Monitoring (optional)

GOUI has the monitoring function.

When monitoring start button is pushed, max. five channel signals are stored in memory (max 3000 data are stored for each channel).

Monitoring screen is as follows, for example.

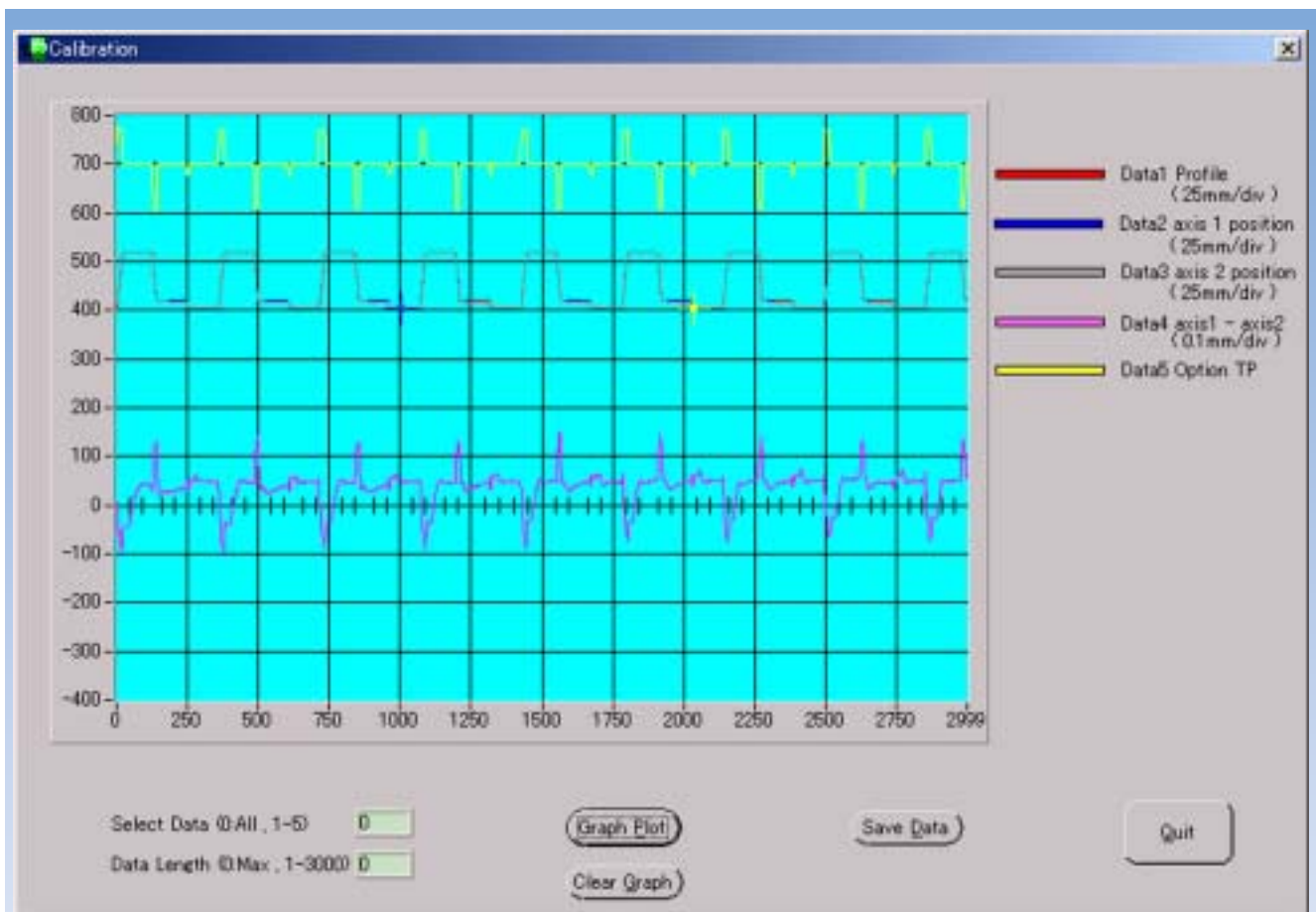

Technical data

Power supply	24VDC / 0.5A
MPU & Memory	MPU : DSP, TMS320C32 (TI) Clock : 50MHz RAM : 32kWord (1Word = 32bit) Flash memory : 256kByte
Analog Input (Ai)	No. of channels : 10ch Resolution : 16bits Input type : Differential input, +/-10V Filtration : 50kHz Input impedance : 100k ohm
Analog output (Ao) for servovalve	No. of channels : 2ch Resolution : 16bits Output type : +/-10V or +/-10mA Filtration : None Output capacity : 1mA for voltage output
Analog output (Ao)	No. of channels : 4ch Resolution : 16bits Output type : +/-10V Filtration : None Output capacity : 1mA (load should be 10k ohm min.)
Digital input (Di)	No. of channels : 16ch Type : Sink/Source Isolation : Optical isolation Input voltage : 15..24Vdc (high level) Input current : 2mA min./ch
Digital output (Do)	No. of channels : 16ch Type : Source Isolation : Optical isolation External Power : 15..24V Output current : 20mA max. Protection : over load protection
Encoder input	No. of channels : 2ch Encoder type : incremental (A,B,Z) Input type : Line Driver Counter range : 24bit Max. pulse rate : 500kHz for each phase A/B
Dimension	49x210x130 (mm)
Operating temperature	0~45°C RH 85% or less no condensation
Storage temperature	-10~60°C
Vibration	10~50 Hz/1G
Weight	0.9Kg

Interface

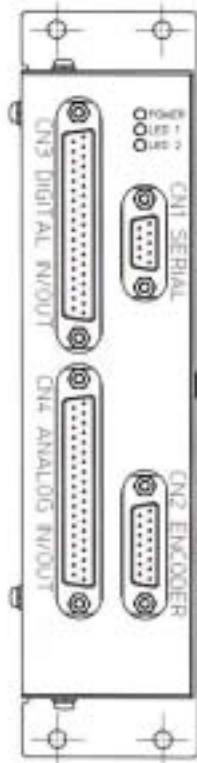

CN –1 Serial

Pin No.	Signal
1	
6	
2	Drive (+)
7	Drive (-)
3	Receive (+)
8	Receive (-)
4	
9	
5	GND

CN –3 DIGITAL IN / OUT

Pin No.	Signal
1	DC24V
20	GND
2	Digital in 1
21	Digital in 9
3	Digital in 2
22	Digital in 10
4	Digital in 3
23	Digital in 11
5	Digital in 4
24	Digital in 12
6	Digital in 5
25	Digital in 13
7	Digital in 6
26	Digital in 14
8	Digital in 7
27	Digital in 15
9	Digital in 8
28	Digital in 16
10	Digital input COM
29	Digital out 9
11	Digital out 1
30	Digital out 10
12	Digital out 2
31	Digital out 11
13	Digital out 3
32	Digital out 12
14	Digital out 4
33	Digital out 13
15	Digital out 5
34	Digital out 14
16	Digital out 6
35	Digital out 15
17	Digital out 7
36	Digital out 16
18	Digital out 8
37	Digital output COM-
19	Digital output COM+

CN –2 Encoder

Pin No.	Signal
1	ENC1 A(+)
9	ENC1 Z(+)
2	ENC1 A(-)
10	ENC1 Z(-)
3	ENC1 B(+)
11	GND
4	ENC1 B(-)
12	GND
5	ENC2 A(+)
13	GND
6	ENC2 A(-)
14	ENC2 Z(+)
7	ENC2 B(+)
15	ENC2 Z(-)
8	ENC2 B(-)

CN-4 ANALOG IN / OUT

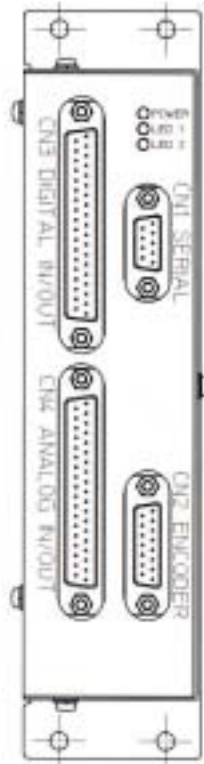

Pin No.	Signal
1	Signal GND
20	Signal GND
2	Analog IN 1 (+)
21	Analog IN 1 (-)
3	Analog IN 2 (+)
22	Analog IN 2 (-)
4	Analog IN 3 (+)
23	Analog IN 3 (-)
5	Analog IN 4 (+)
24	Analog IN 4 (-)
6	Analog IN 5 (+)
25	Analog IN 5 (-)
7	Analog IN 6 (+)
26	Analog IN 6 (-)
8	Analog IN 7 (+)
27	Analog IN 7 (-)
9	Analog IN 8 (+)
28	Analog IN 8 (-)
10	Analog IN 9 (+)
29	Analog IN 9 (-)
11	Analog IN 10 (+)
30	Analog IN 10(-)
12	Signal GND
31	Signal GND
13	Analog OUT 1
32	Current OUT1 (-)
14	Analog OUT 2
33	Current OUT1 (+)
15	Analog OUT 3
34	Current OUT2 (-)
16	Analog OUT 4
35	Current OUT2 (+)
17	Analog OUT 5
36	
18	Analog OUT 6
37	Signal GND
19	Signal GND

Installation

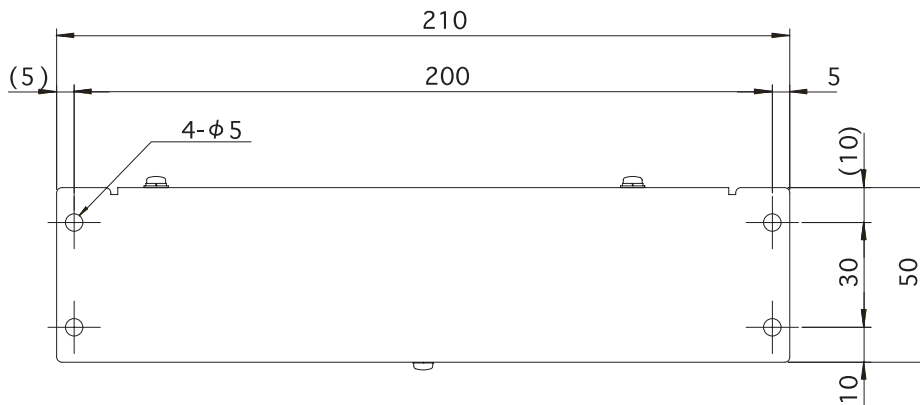
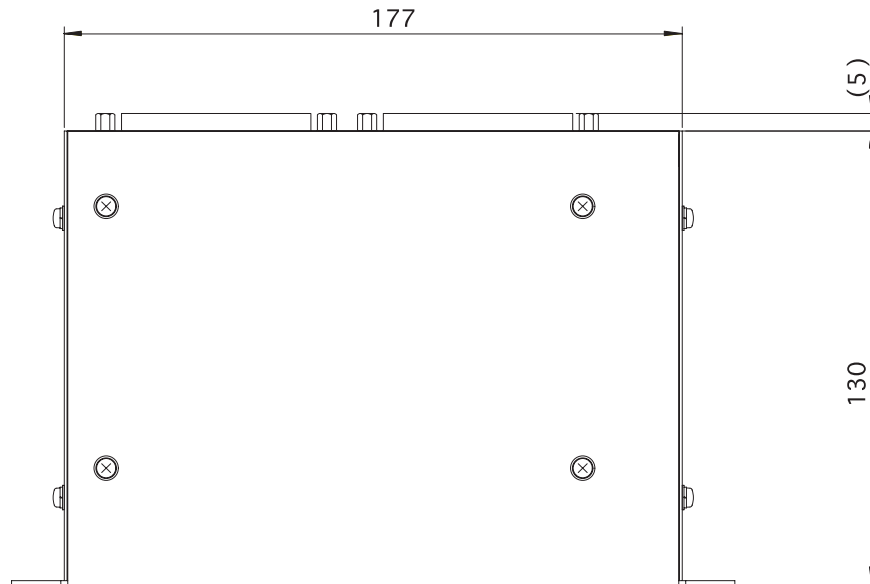
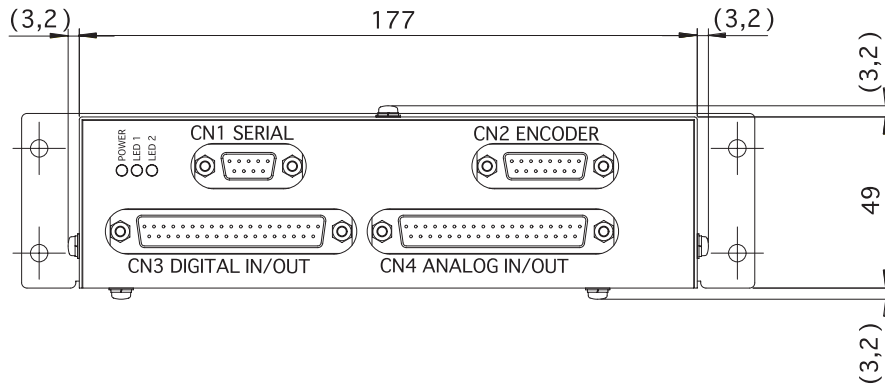

Ordering information

1. Controller

This controller Model No. is J124-04x-xxx
Second and third dash No. is applied for each application.

- (1) Digital Servo Controller :Model J124-046,
the hardware (J124-040-001)with the control application software which is stored in the flash memory.
- (2) GOUI package:
Windows based HMI to adjust gain parameter by PC (Part No. Cxxxxx-xxx: 3.5inch, 2HD)

2. Accessory

● Mating connector for controller:

- (1) A47700-062: Socket 15P D-sub(female) 1pc
- (2) A47700-064: Socket 37P D-sub(male) 1pc
- (3) A47700-119: Socket 37P D-sub(female) 1pc
- (4) A47700-121: Hood kit 15P D-sub 1pc
- (5) A47700-122: Hood kit 37P-D-sub 2pcs

● Serial communication part and cable Assay

- (1) C14952-002: Cable assembly for RS232 serial communication
- (2) C14953-003: Cable assembly for RS422 serial communication
- (3) A47733-026: RS232/422 converter
- (4) A47733-036: AC adapter for converter

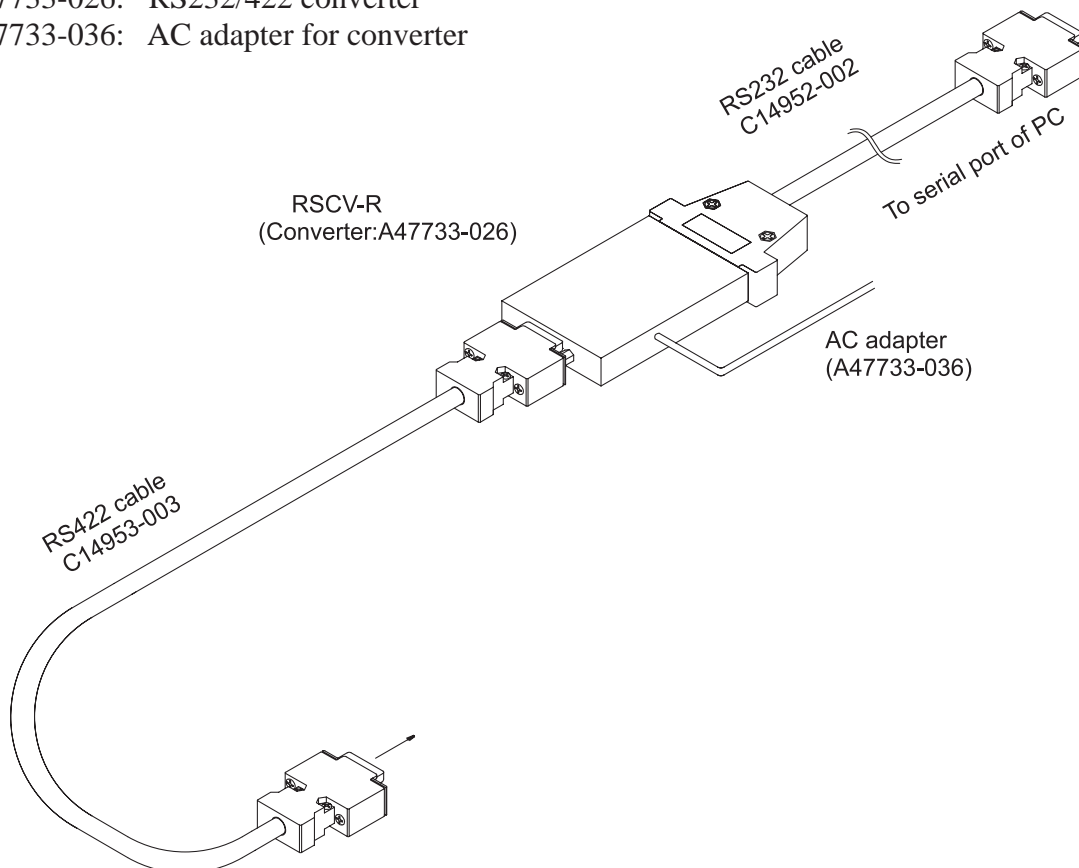



Argentina
Australia
Austria
Brazil
China
Finland
France
Germany
India
Ireland

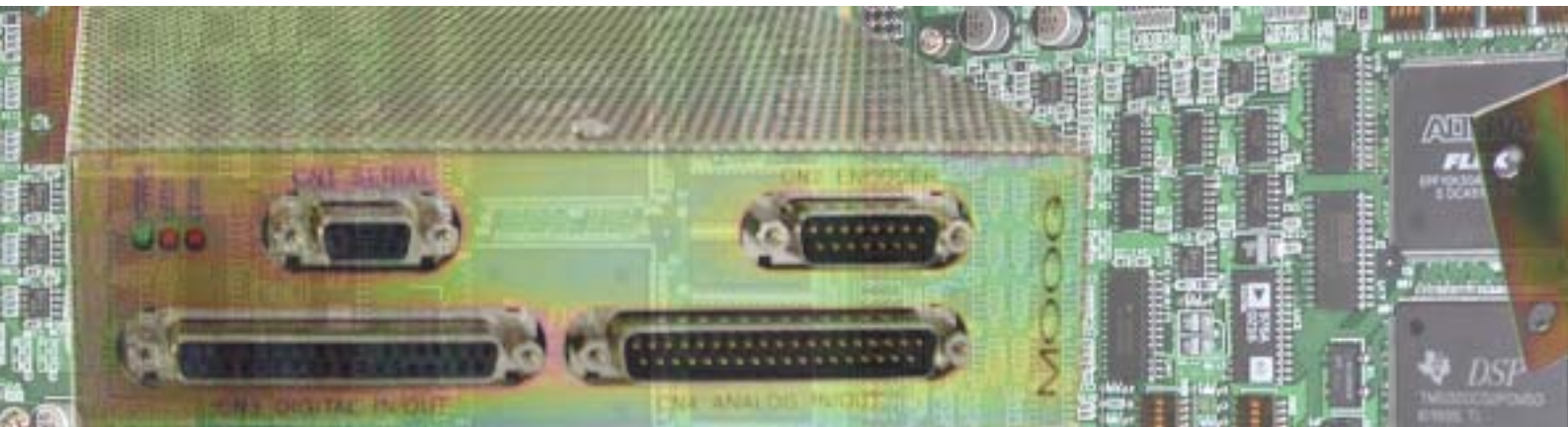

Italy
Japan
Korea
Luxembourg
Norway
Russia
Singapore
South Africa
Spain
Sweden
United Kingdom
USA

This catalog is for users with technical knowledge. To ensure that all necessary characteristics for function and safety of the system are given, the user has to check the suitability of the products described herein. The products described herein are subject to change without notice. In case of doubt, please contact Moog.

Moog is a registered trademark of Moog Inc. and its subsidiaries.
All trademarks as indicated herein are the property of Moog Inc. and its subsidiaries.
© Moog Inc. 2003. All rights reserved.
All changes are reserved.
For the most current information, visit [www.moog.com/\(insert product name\)](http://www.moog.com/(insert product name))

MOOG

Moog Japan Ltd.
1-8-37 Nishi Shinndo, Hiratsuka,
Kanagawa-ken, Japan 254-0019
Tel : +81-463-55-3615
Fax: +81-463-54-4709
USA: +1-716-655-3000
Germany: +49-7031-622-0
Italy: +39-010-96711
For the location nearest you, contact
www.moog.com/worldwide